

NEY Product Information



Data Sheet

110° Hinge

Hinges & Lift Systems



NEY Ltd (Head Office)
Stonebridge Trading Estate
Sibree Road
Coventry
CV3 4FD

t 024 7630 8100
f 024 7630 8101
e sales@ney.co.uk

NEY Ireland
Unit 22 Blaris Ind Estate
Altona Road
Lisburn
BT27 5QB

t 028 92 673 000
f 028 92 672 999
e ireland@ney.co.uk

NEY Scotland
Block 2 Units 1-2-3
Bandeath Ind Est
Throsk, Stirling
FK7 7NP

t 01786 814 814
f 01786 814 812
e scotland@ney.co.uk



- Opening angle 110°
- Cup diameter 35mm
- Cup depth 11.2mm
- Nickel Coating

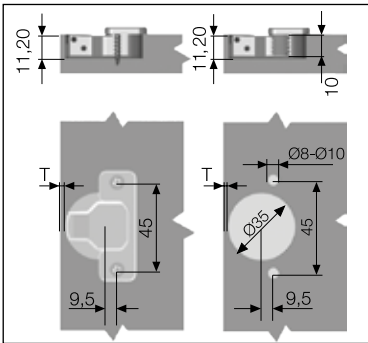

CLIP ON



OVERLAY	0mm
Pack Qty: 250	
Item Number	Description
110698	No Screw
110706	8mm Dowel

HALF OVERLAY	9mm
Pack Qty: 250	
Item Number	Description
110699	No Screw
110707	8mm Dowel

INSET	18mm
Pack Qty: 250	
Item Number	Description
110700	No Screw
110708	8mm Dowel

SLIDE ON



OVERLAY	0mm
Pack Qty: 250	
Item Number	Description
110681	No Screw
110689	8mm Dowel

HALF OVERLAY	9mm
Pack Qty: 250	
Item Number	Description
250248	No Screw
110690	8mm Dowel

INSET	18mm
Pack Qty: 250	
Item Number	Description
110683	No Screw
110691	8mm Dowel

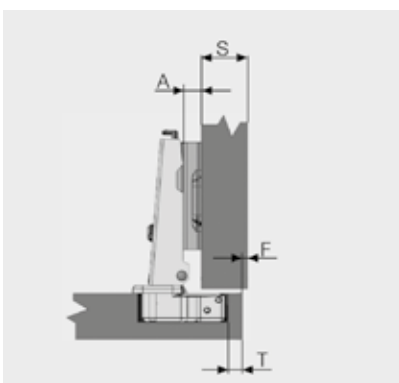

Formula: $A = 18 + F + T - S$

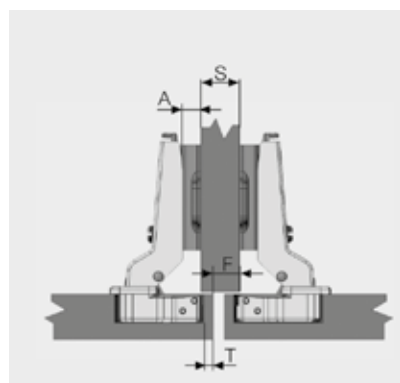

Formula: $A = 9 + F + T - S$

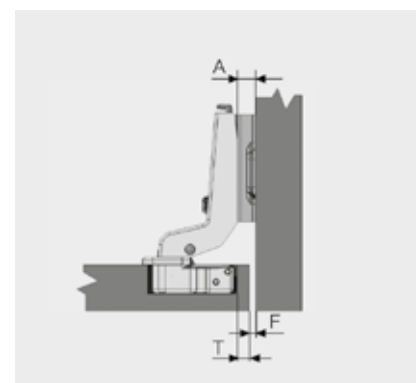

Formula: $A = F + T$

Calculation tables

S	Side Thickness	18				15	
A	Mounting Plate Thickness	5	7	7	7	9	9
F	Minimum Gap	1	1	2	1	1	2
T	Cup Distance	4	6	5	4	6	5

S	Side Thickness	18				15	
A	Mounting Plate Thickness	5	7	7	7	7	-
F	Minimum Gap	10	10	11	9	10	-
T	Cup Distance	4	6	5	5	4	-

S	Side Thickness	18				15	
A	Mounting Plate Thickness	5	7	7	-	-	-
F	Minimum Gap	1	1	2	-	-	-
T	Cup Distance	4	6	5	-	-	-

KEY: Used In Elite Hinge Formula Tables

Key

DOOR THICKNESS **K**



CUP DISTANCE **T**

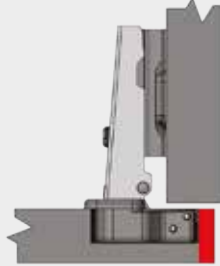

FUGA **F**



SIDE WALL THICKNESS **S**



MOUNTING PLATE THICKNESS **A**



CUP DRILLING DIAMETER **D**

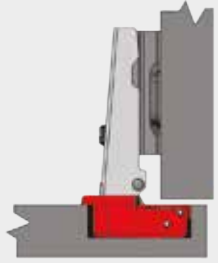

MINIMUM GAP **G**

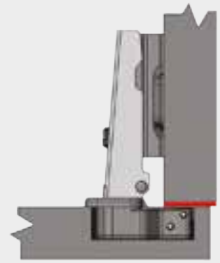

OVERLAY **B**

